

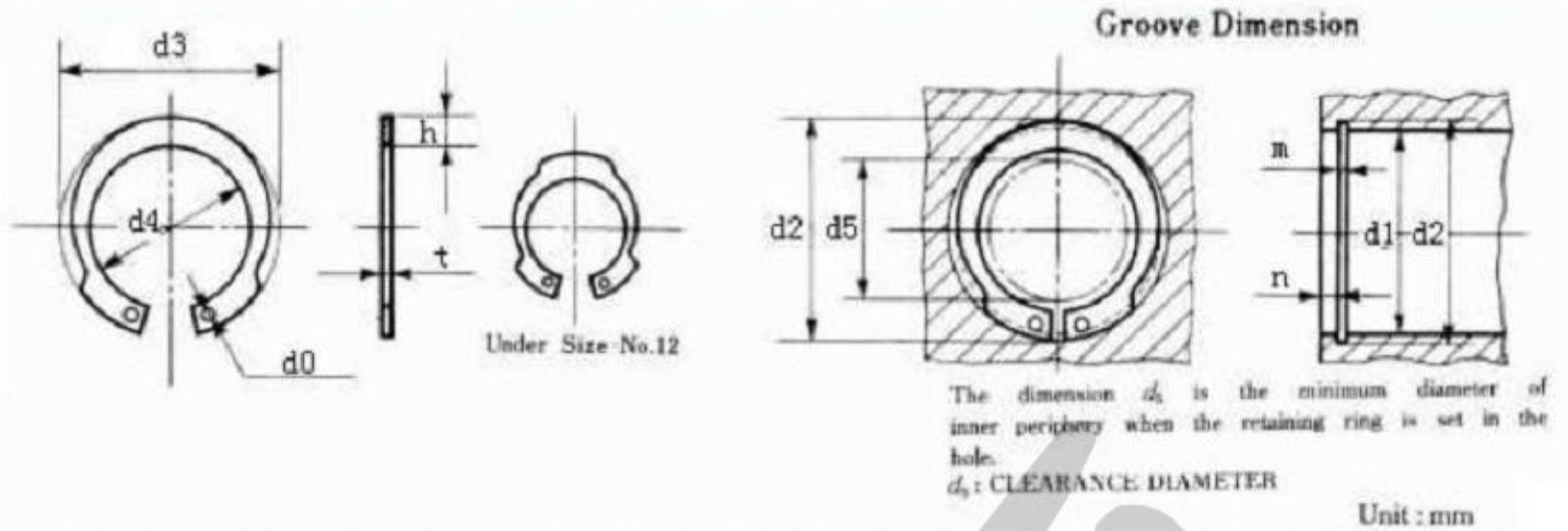

# IRTW 反向孔用扣環

碩恆精密五金有限公司  
 Web: www.shwjsy.com  
 E-mail: info@shwjsy.com  
 TEL: 0769-85129020/85129050  
 89874068 FAX: 0769-82882032



IRTW	Ring dimension								Groove dimension						
	d3		d4	t		h	d0	Gen. Tol.	d5	d1	d2		m	n	
	Bas.	Tol.	Bas.	Tol.	Bas.	Tol.				Bas.	Tol.	Bas.	Tol.	Min.	
	10	11.1	±0.18	7.7	1.0	±0.05	1.7	0.9	±0.3	5.9	10	10.4	+0.11 -0.00	1.15	1.5
	11	12.2		8.6			1.8			6.6	11	11.4			
	12	13.3		9.7			1.8			7.6	12	12.5			
	13	14.1		10.9			1.6			9.0	13	13.6			
	14	15.1		11.7			1.7			9.8	14	14.6			
	15	16.2		12.6			1.8			10.6	15	15.7			
	16	17.3		13.5			1.9			11.4	16	16.8			
	17	18.3	14.3	2.0	12.2	17	17.8								
	18	19.5	15.3	2.1	13.0	18	19.0								
	19	20.5	16.1	2.2	13.8	19	20.0								
	20	21.5	16.9	2.3	14.5	20	21.0								
	21	22.5	17.7	2.4	15.0	21	22.0								
	22	23.5	18.7	2.4	16.0	22	23.0								
	24	25.9	20.7	2.6	17.5	24	25.2								
	25	26.9	21.5	2.7	18.5	25	26.2								
	26	27.9	22.3	2.8	19.0	26	27.2								
	28	30.1	24.1	3.0	20.5	28	29.4								
	30	32.1	25.7	3.2	22.5	30	31.4								
	32	34.4	27.4	3.5	23.5	32	33.7								
	34	36.5	29.1	3.7	25.0	34	35.7								
	35	37.8	30.0	3.9	26.0	35	37.0								
	36	38.8	30.8	4.0	26.5	36	38.0								
	37	39.8	31.6	4.1	27.5	37	39.0								
	38	40.8	32.4	4.2	28.0	38	40.0								
	40	43.5	34.7	4.4	30.0	40	42.5								
	42	45.5	36.3	4.6	31.0	42	44.5								
	45	48.5	38.9	4.8	33.0	45	47.5								
	47	50.5	40.7	4.9	35.0	47	49.5								
	48	51.5	41.5	5.0	36.0	48	50.5								
	50	54.2	44.0	5.1	38.0	50	53.0								
	52	56.2	45.8	5.2	40.0	52	55.0								
	55	59.2	48.0	5.6	42.0	55	58.0								
	56	60.2	48.8	5.7	43.0	56	59.0								
	58	62.2	50.4	5.9	44.0	58	61.0								
	60	64.2	52.0	6.1	46.0	60	63.0								
	62	66.2	53.6	6.3	47.0	62	65.0								
	63	67.2	54.4	6.4	48.0	63	66.0								
	65	69.2	55.8	6.7	49.0	65	68.0								
	68	72.5	58.5	7.0	52.0	68	71.0								
	70	74.5	60.1	7.2	53.0	70	73.0								
	72	76.5	61.7	7.4	55.0	72	75.0								
	75	79.5	63.9	7.8	57.0	75	78.0								
	78	82.5	66.3	8.1	59.0	78	81.0								
	80	85.5	68.9	8.3	61.0	80	83.5								
	※ 82	87.5	70.5	8.5	62.0	82	85.5								
	85	90.5	72.7	8.9	64.0	85	88.5								
	※ 88	93.5	75.1	9.2	67.0	88	91.5								
	90	95.5	76.7	9.4	68.0	90	93.5								
	※ 92	97.5	78.3	9.6	70.0	92	95.5								
	※ 95	100.5	80.5	10.0	72.0	95	98.5								
	※ 98	103.5	82.9	10.3	75.0	98	101.5								
	100	105.5	84.5	10.5	76.0	100	103.5								

Material=carbon spring steel.(stainless spring steel)

Hardness=HRC44-52

Finish=Black phosphate coating(ACP)

Note:※ Mark are according to our company specification